

Hawk Talks



A Publication of the Karel Staple Chapter of the Studebaker Drivers Club

This story was recently published in the Appeal newspaper in Marysville!
Nice to see Studebaker stuff in other publications.

TODAY IN HISTORY

Appeal Staff Report

Raymond Loewy, designer

On March 22, 1961, industrial designer Raymond Loewy made several sketches of a futuristic sports car at the request of Sherwood Egbert, the recently appointed president of the ailing Studebaker Corporation. Egbert hoped that Loewy, who had a long relationship with the company, could design a new car bold enough to capture the popular imagination and boost the company's sagging fortunes. Loewy and his team of designers produced a prototype automobile in record time; the Avanti — Italian for "forward" — debuted in April 1962 to rave reviews. The four-passenger car was indeed forward-looking, for it had a streamlined fiberglass body with almost no chrome, and was the first American car to incorporate a disc brake system along with other safety features.

A series of problems stalled production of the car, however, and the Studebaker Corporation abruptly discontinued its U.S. manufacture late in

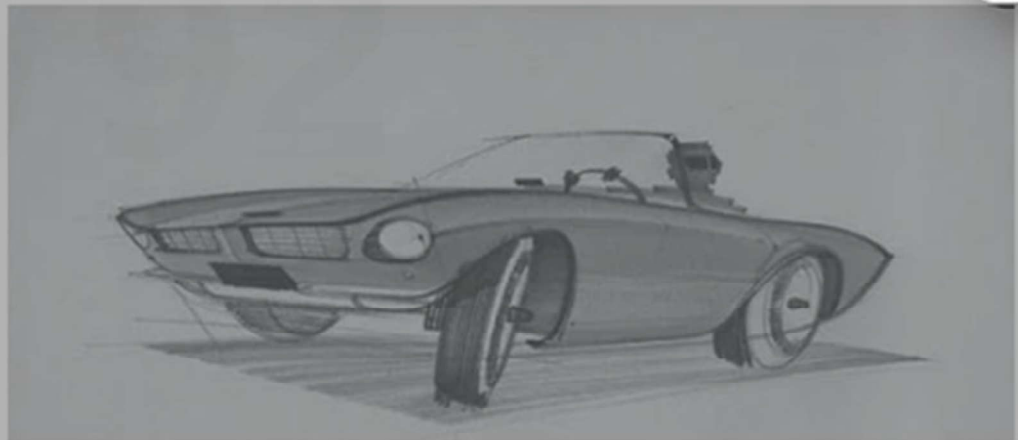

Library of Congress

Preliminary Studies for Studebaker "Avanti" Automobile. Raymond Loewy, fluid marker on paper, March 22, 1961.

1963. Seeking to revive the popular model, in 1965 two Studebaker dealers acquired the corporation's vacated South Bend, Indiana factory and as the Avanti Motor Corporation produced the Avanti II into the 1980s.

Raymond Loewy, who is sometimes called "the father of industrial design," also designed automobiles for Hupmobile, Lincoln, and Jaguar, among many other projects. Born in Paris in 1893, he was educated

in France as an engineer. Loewy emigrated to the United States after World War I, where his first design assignments were in window decoration for New York department stores. Loewy's signature streamlined style was eventually seen in a wide variety of industrial and consumer products, ranging from railroad locomotives to refrigerators, to pencil sharpeners, to dishes, to corporate logos. He became a U.S. citizen in 1938 and married Viola Erickson 10 years

later. Never Leave Well Enough Alone, Loewy's autobiography, appeared in 1951. In the early 1960s, Loewy was hired by the Kennedy White House for several projects; he also designed a commemorative postage stamp in memory of John F. Kennedy, in 1964.

By 1967 he was employed by NASA to create hospitable spaces for astronauts. Raymond Loewy died in 1986.

Source: Library of Congress

Page 2...President's Message....By Steve Rainville Meeting Minutes ...by Betty Martin

Dues are due now! From Johanna Smith, Dick Grove

Page 3... Tech Tip, Wanted and For Sale

Page 4... KSC Meeting Schedule, Directions to April Studebaker Picnic

Page 5... Membership Info

President's Message
by Steve Rainville

Hello Everybody

I hope all of you are well and looking forward to our next get together. Spring is trying to start but a few storms keep showing up. I'm sure we all know that rain and snow are needed just not on the dates we meet.

April brings Lou's picnic in Stockton always a good one sometimes a little windy but a fun time. I'm hoping the warmer weather brings more of our club members and their cars. Did I mention food?

Just a last thought we still need a secretary and an editor for the news letter.

I know that a note about Dick Grove passing away has been sent out. I will surely miss him, as all who knew him will.

Yours Truly Stephen Rainville

March Meeting Minutes
by Betty Martin

Meeting was held on March 16, at Brookfields Restaurant in Roseville, Ca. Nineteen members present, including both Johna and Linda. There were no guests.

Steve brought the meeting to order.

Old Business:

Steve mentioned the club needs a permanent secretary and editor. Betty Martin filled in as secretary and is selling raffle ticket sales until Linda Barnard is off medical leave. There was no treasurer's report.

New Business:

Pamphlets arrived and Betty Knopf worked on tri-folding them during the meeting.

There has been a question as to the pronunciation of Karel Staple. After Steve's research, it was found that Karel is pronounced like Karl not Carol.

The August Meeting was shown as Friday the 16th. It was voted on that the meeting will be changed to Sunday the 18th at the Auto Musuem. Johna will verify the date with the musuem. There was a question about the October Meeting and the International Car Show, so the date and place will be confirmed at a later date.

Requests for sweatshirts are back so Johna will ask the graphic artist about artwork. .Continued to the next meeting.

Next Meeting is April 28, and hosted by Lou at Fritz Grupe Park in Stockton.

La Ree let everyone know Skyler sold his Lark!!! Joe Burch won \$40 in the 50/50 Drawing and Perry Knopf won the Car Show Certificate!!!

Breakfast was great and our server very pleasant, Just a little noisy in the Restaurant....

Hello Members!

I am trying to wrap up the dues for 2024. April 1st is the deadline for the 2024 dues payment.

If you would like to continue receiving the monthly newsletter, please send in your dues or shoot me an email and let me know if you would like to continue with your membership.

Dues are \$20.00 annually. Please make checks payable to: Karel Staple Chapter and

Mail to:

Karel Staple Chapter
c/o Johanna Smith
PO Box 10529

Napa, CA 94581-0529

These are the members who have not renewed yet. We hope all will continue as members.

Andersen, D	Parker
Bates	Pavao
Brayton	Petersen, C
Brewer	Salazar
Fentress	Shaw
Gibbs	Sumner
Gibson	Valdez
Grant	Wecker
Hadley	Wunderlich
Hodges	Zarins



We lost Dick Grove on 3/22/2024. He and Norma were great contributors at our Zone meets. They were always willing to travel and bring along the Valve Cover Race track. He was a great Studebaker advocate who was willing to share. knowledge.

Hydraulic Brake Light Switch Fix Option #2 By Jim and Karen McKeever SJVC/SDC

I was doing a maintenance check the other day before taking my Model A "roadster-baker" out for a spin when I noticed I had no brake lights!

Sure enough, my hydraulic brake light switch was bad, so I decided I would take my own advice and install a new one along with the horn relay modification I wrote about earlier in the year.

I had a new brake switch on hand but not a standard horn relay and I was too impatient to wait for an Amazon delivery. I did however have a 4 pin, 12-volt, 30/40-amp multi-purpose relay so I used it instead.

The installation procedure for using a multi-purpose relay is similar to the one using the standard horn relay, but instead of working with terminals marked B, S, and H you are working with terminals marked 85, 86, 87, and 30, which need slightly different wiring.

- Begin by removing the wires from the brake light switch. Using a test light/meter, identify the wire to the battery versus the wire to the brake lights and label them. Then unhook the negative terminal to the battery to remove and replace the old switch.

- Install the new brake light switch without hooking up any wires.

- Mount the multi-purpose relay in a convenient spot, using the appropriate wire connectors for your application.

- Connect the battery wire (power wire from the fuse box) to terminal 30 on the relay.

- Run a jumper wire from terminal 30 to terminal 86 on the relay.

- Connect the brake light wire to terminal 87 on the relay.

- Run a new wire from one terminal on the brake light switch to terminal 85 on the relay. (The brake light switch does not care which of its two terminals you use.)

- Run a new wire from the other terminal on the brake light switch to a spot on the metal body, drilling a hole as necessary, (check for what is on the other side before drilling) and mount with an eyelet connector and screw, placing a star washer between the eyelet and the metal body.

- 14-16 gauge wire is adequate for the new wires.

You can also use a 5-pin relay with the 87a terminal on it, just don't attach anything to 87a.

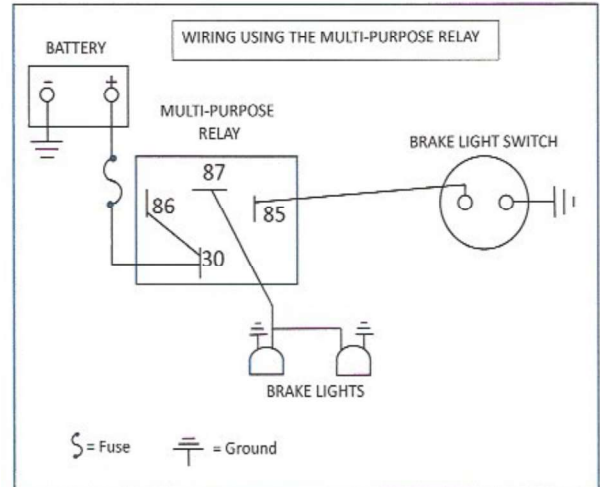

Thanks To Dan Dobbins

Ever try and remove exhaust manifold bolts from a '64 Studebaker V8 engine? Difficult, huh? Round off the bolt heads huh? "Wanna" know why? Studebaker changed the metallurgy of it's exhaust manifold bolts after the '63 model year. Made 'em from a softer Grade 5 instead of the harder Grade 8. To do a good job, you're "gonna" need special extraction tools. And replace them with Grade 8, 1 1/20 3/8" course thread bolts, readily available from your local Hardware Store.

For Sale and Wanted

For Sale:

1950 2R5 Pick Up \$6000 For Details call Gary Nordstrom 530 354 4766

1959 Pick Up \$8500 Call Steve for the Particulars! 916 899 1135

1963 Larks (Plenty to go around!!! There's 5 of them) Call Brian Challender 916 880 8877

STUDEBAKER

La Palma

CAR SHOW & PARTS EXCHANGE

50 Years

1974 - 2024

THE LARGEST
STUDEBAKER
MEET IN THE WEST!

Sunday, May 26, 2024
8:00 am - 3:00 pm

Celebrate our Anniversary
with us!!

La Palma Park, Anaheim, CA

www.StudebakerSoCal.com

KSC CALENDER 2024
Bold Dates are Karel Staple events

Apr 28 Sunday Studebaker Rambler Picnic, 11 am Grupe Park, Stockton, BYO picnic lunch Host Lou Van Anne

May 18 Saturday Sutter Buttes Cruise, Host Betty and Perry Knopf

Jun 15 80th Studebaker Wheelbarrow Race, El Dorado County Fair. Host Pat Dilling

Jun 22 Saturday Annual Chapter Auction, 11 am Pat & Kate Dilling's home, 4074 Mary Ave, Olivehurst. Pot Luck, Bring things to auction. Proceeds to Chapter.

Jul 20 Saturday Johanna & Frank Smith's home, 11am Pot Luck

Aug 16 Friday California Auto Museum, 11 am, 2200 Front St, Sacramento, Hosts Johna & Rick Pierce

Sep 15 Sunday IDYSD Western Railway Museum, 11 am, 5848 CA-12, Suisun City, BYO lunch, Host Linda Barnard

Oct 18-20 International Auto Show, Cal Expo, Host Pat Dilling

Oct 20 Sunday Mark & Monica's Pizza, 11 am, 4751 Manzanita Ave, Carmichael, Hosts Pat & Kate Dilling

Nov 16 Saturday, Back 40 Texas BBQ 11 am, 1201 Orlando Ave, Roseville, Host Johna Pierce

Dec 7 Saturday Christmas Party, Christ Community Church, 5025 Manzanita, Carmichael, 11:30

Sunday April 28th 2024 will see this year's largest gathering of Studebakers and Ramblers in Northern California. (We have never had less than 20 Studies and 10 Ramblers). The Sequoia, San Joaquin Valley and the Karel Staple Chapters of the Studebaker Drivers Club will Join AOAI's Avanti LTD and the Pacific Gold Rush Ramblers for our 23rd Annual Picnic. If you are a Studebaker, Avanti or Rambler/AMC admirer join us at Grupe Park, Stockton CA. The South east parking lot (Google the intersections of Sea Gull and Landview Dr.) has been reserved for our exclusive use. Folks begin arriving around 11:00 AM. Two BBQ grills along with plastic utensils, paper plates and bottled water will be provided. Bring your own chairs, picnic lunch, or hot dog/hamburgers to grill and a side dish to share. PM me for more info if needed.

Lou VanAnne



Directions to the April Picnic

Fritz Grupe Park, Stockton 11:00 am, Exit I-5 at Benjamin Holt Dr, Turn West. Follow it to Cumberland Pl. and turn left, then follow to Meade Dr and turn left and follow around the park to the South East parking lot at Sea Gull Lane.

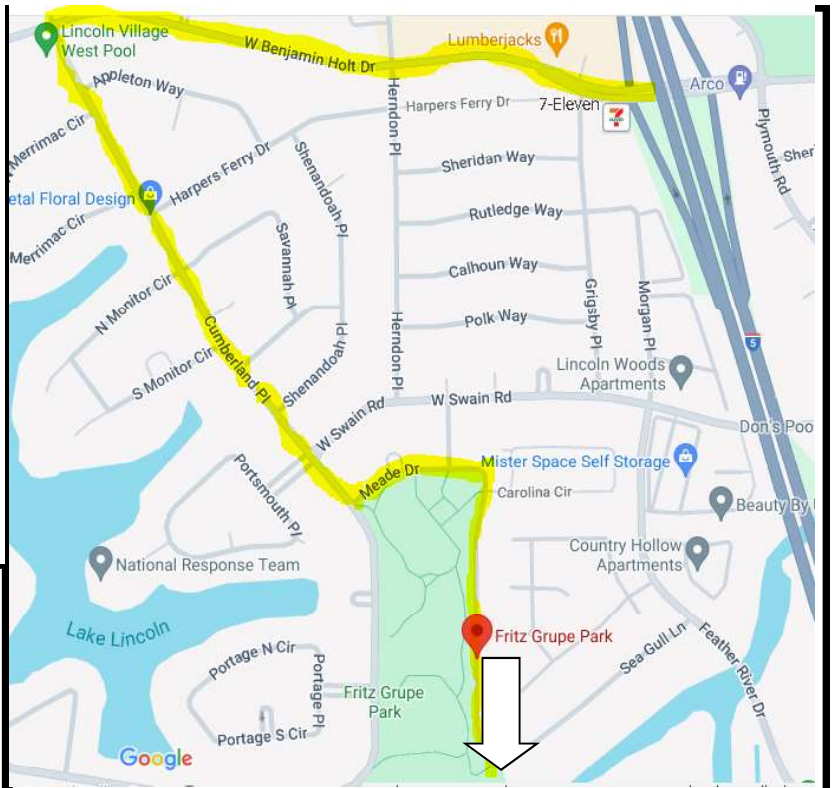

National SDC Application

Karel Staple Chapter Application

**For SDC National membership:
Please mail check or money order**

to:

**Studebaker Drivers Club, Inc.
P.O. Box 1715
Maple Grove, MN 55311-6715**

**Includes monthly publication of
Turning Wheels Magazine**

- ___ First year membership w/periodicals class mail \$29.00
- ___ Regular membership w/periodicals class mail \$36.00
- ___ Regular membership w/ first class mail \$62.00
- ___ Student/young adult (up to 22 years old) \$29.00
- ___ SDC membership without Turning Wheels \$12.00

To use Visa or Mastercard call:
(763)420-7829 fax (763) 420-7849
or email: sdc@cornerstonereg.com for more information.

Name: _____
Spouse: _____
Address: _____
City: _____ St: ___ Zip: _____
Phone: _____
Email: _____

If new member, source of referral:

Please list Studebakers, including Year, make, body style on separate page.

All members of local chapters must be members of the National Studebaker Drivers Club
SDC #: _____

Membership dues are \$20 Annually

Name: _____
Address: _____
City: _____ St: ___ Zip: _____
Phone: (____) _____
Email: _____
Referred by: _____
Birthday (Mo) _____ Spouse: _____

___ YES, I would like my newsletter emailed to me each month.
___ NO, I would not like my information to be published on our roster.

Please list Studebaker (s) owned:

1. _____
2. _____
3. _____
Year Model Body type

Name Badge Application:

Name: _____
(may be a nickname)
Spouse: _____
Name badges are \$12.00 each \$ _____
Membership fee: \$ 20.00
Total enclosed: \$ _____

Make check payable to:

Karel Staple Chapter SDC

Mail to: Johanna Smith
PO Box 10529
Napa, CA 94581
(707)255-7108

Karel Staple Chapter Officers

President - Stephen Rainville
Citrus Heights, CA

(Vice President - Frank Smith
Napa, CA

Treasurer - Lou Van Anne
Stockton CA 95219

Secretary - Vacant

Membership - Johanna Smith
PO Box 10529
Napa, CA 94581
(707) 255-5108

Email: karelstaplesdc@yahoo.com

Editor - Pat Dilling

P.dilling@outlook.com

Webmaster - Jason Michaels - jason@jasonmichaels.com

National Officers

President - Dennis Foust
143 Studebaker Rd
Spring Hills, PA 16875
Studeguy54@gmail.com

Vice President - Don Jones
PO Box 229
Concord, VA 24538
keydetsdj@aol.com

Secretary - Cindy Foust
143 Studebaker Rd
Spring Hills, PA 16875
cfoust1966@gmail.com

Treasurer - Jane Stinson
5800 Stanley Rd
Columbiaville MI 48421
jestinson@aol.com

Past President—Tom Curtis
3538 Gordon Rd
Elkhart, IN 46516

Pacific Southwest Zone Officers

National Director, Board of Directors -

Zone Coordinator -
Ed Smith
PO Box 90763
White Mtn Lake, AZ 85912
edcollects@cox.net

Regional Manager, California-
Lou Van Anne
Stockton, CA 95219
lvasales@comcast.net

For insurance purposes and also to comply with SDC Bylaws governing chapters, all members of a local chapter must also be a member of the National Club. Don't forget to renew your National membership.

Visit us at:
www.Hawktalks.com
For a look at the pictures in color

Hawk Talks
Karel Staple Chapter
4074 Mary Ave
Olivehurst, CA 95961